

## Gear Drive

### Clamp-mount XJA Series air drive mixers

Operate wherever compressed air is available.

- 1/3, 1 and 3 hp
- Safe for use in flammable or explosive environments.
- Air control valve varies speeds.
- Impossible to burn out the motor, even with a stalling overload.
- Lightweight design for easy handling.

### Energy efficient DURA-MIX™ Motors

Designed Specifically For Mixer Service

- 6-8 percentage points higher than a standard efficient motor.
- Can be wired from 200 VAC to 480 VAC, 50 or 60 Hertz, 3 phase.
- Class FJ insulation better suited to withstand overloads or adverse conditions than Class B insulation.
- Thermostats can be wired in series with starter relay or connected to alarm. Single-phase motors have built-in manual reset circuit breakers.
- Available explosion-proof motors are available in 1/4 to 3.5 hp which meet NEC requirements for Class I, Group D and Class II, Groups F and G. Thermal protector shuts off unit if operating temperature exceeds safe limits.

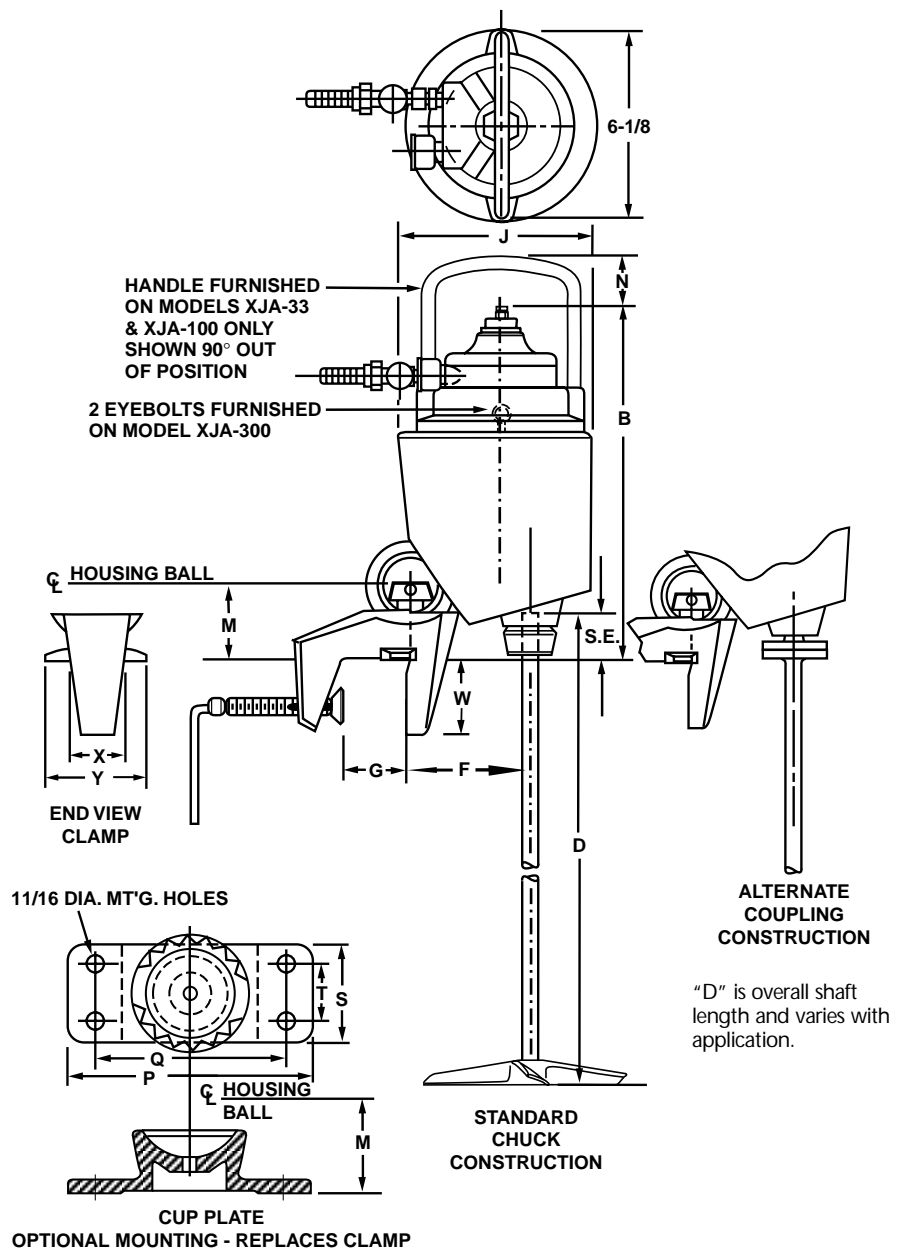
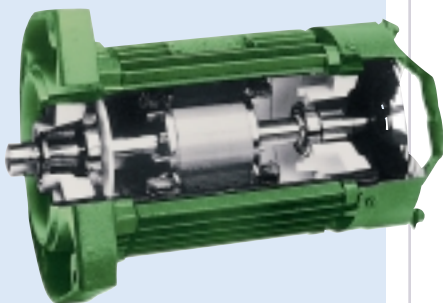

CLAMP MOUNT, GEAR DRIVE XJA SERIES AIR DRIVE MIXERS																
Model	hp	Max. Wt. Lbs.	S.E.	B	F	G	J	M	N	P	Q	S	T	W	X	Y
XJA33	.33	45	4.00	12.6	5	3	8.0	3.44	2.38	9	7	3.5	2	3.13	2.38	5.19
XJA100	1	65	4.88	14.5	5.5	3.75	8.25	4.19	1.5	10	8.5	3.63	2	3.5	2.88	5.75
XJA300	3	120	4.62	20.25	6.5	3.75	10.25	4.50	-	10	8.5	4	2.5	4.19	3.25	6.88

AIR PRESSURE/AIR CONSUMPTION GUIDE		
Model hp	PSIG	CFM (Free Air)
.33	60	15
1	85	30
3	70	96