



Item No: _____

Somat Model : HE-6S-3

Technical Specs:

Hydra-Extractor: Rigid stainless steel weldment with aluminum stand, head assembly with 3 HP TEFC drive motor mounted to a **20:1 gear reducer**, **17" long stainless steel discharge chute** with limit switch, chemical additive pump, automatic rinse system. **Water extractor mechanism consists of 6" diameter stainless steel screw with nylon brush edge, stainless steel plug cutter and matching 6" diameter reinforced stainless steel screen.**

Valve Package: All valves required for proper operation (automatic rinse system).

Som-A-Trol® (Electrical Control Panel): UL approved. Includes all necessary electrical components prewired to a terminal strip in a NEMA 4 stainless steel enclosure.

Options Available:

- Extended discharge chute
- Hinged Chute
- Extended stand
- Special electrical characteristics
- Pulp level detector

Special Requirements:

- 7-1/2 HP, 10 HP or larger return pump, Determined by piping conditions.
- Water economizing tank. Required when 7-1/2 HP or larger return pump is used.
- Pulp Screw Conveyor and controls. Required to convey pulp from discharge chute to haul-away container when location of container does not permit gravity discharge.

Electrical Characteristics: 208/230/460 volt,

3 Phase, 60 Hertz

Capacity: 1600 pounds per hour of foodservice waste mix, consisting of food scraps, plastics, milk cartons, paper, aluminum foil and cardboard.

Finish: All exterior surfaces are stainless steel.

Equipment only is supplied by Somat Company; installation, piping and wiring not included.

DESCRIPTION:

Standard SOMAT® Model HE-6S-3 Hydra-Extractor® with 3 HP drive motor, 3 HP or 5 HP return pump, chemical additive pump, automatic rinse system, valve package, Som-A-Trol® control panel and discharge chute with limit switch.

Benefits

- As much as 8 to 1 (87.5%) volume reduction
- Reduced labor cost
- Better sanitation
- Water conservation
- Improved operator morale
- Reduced silverware loss

Processes a wide variety of waste

Operation: Slurry, consisting of 5% solids and 95% water, is automatically transported through a pipeline after being processed in the pulper(s) to the Hydra-Extractor, where water is removed and the resultant semi-dry pulp is discharged into a haul-away container. The extracted water is recovered and returned to the pulper(s) for re-use. The capacity of the Hydra-Extractor determines how many pulpers can be designed to operate with it concurrently.

Somat equipment provides an economic and efficient answer to cutting the high and ever increasing costs associated with waste handling. Manufactured by Somat Company of Lancaster, Pennsylvania, originators of waste pulping systems and specialists in waste reduction technology.

Somat Company—Division of ITW Food Equipment Group LLC
 165 Independence Ct., Lancaster, PA 17601 USA
 Phone: 717-397-5100 / 800-237-6628 Fax: 717-291-0877



HE-6S-3 Remote Pulping System Elevation / Plan Views

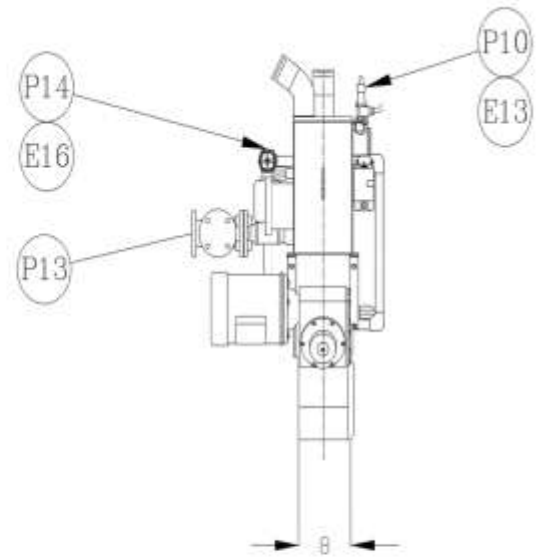
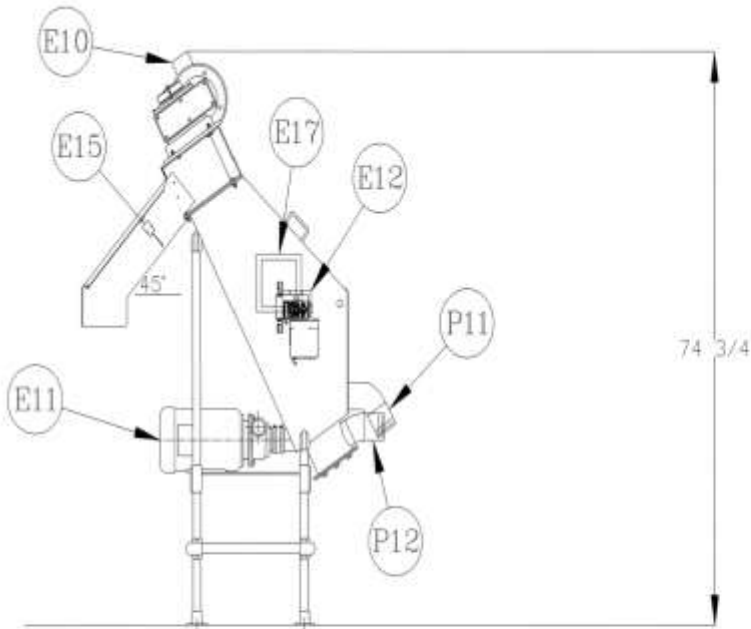

ELEVATION VIEW OF HE-6S-3 EXTRACTOR

PLAN VIEW OF HE-6S-3 EXTRACTOR

Utility Connections

E10- Extractor Drive Motor (3Hp)	P10- Fresh Hot Water Inlet
E11- Return Pump Motor (3Hp / 5Hp)	P11- Overflow Outlet
E12- Chemical Additive Pump	P12- Slurry Inlet
E13- Fresh Hot Water Solenoid	P13- Return Water Outlet
E14- N/A	P14- Autorinse to Drain
E15- Chute Limit Switch	
E16- Autorinse MOV	
E17- Junction Enclosure	

Dimensions

Height: 75" (1905mm)	Equipment weight: 525lbs
Length: 41" (1042mm) (Not including chute)	Operating weight: 570lbs
Width: 33" (839mm)	Crated weight: 625lbs
	Crated volume: 59 cu. Ft.

WIRING DIAGRAM

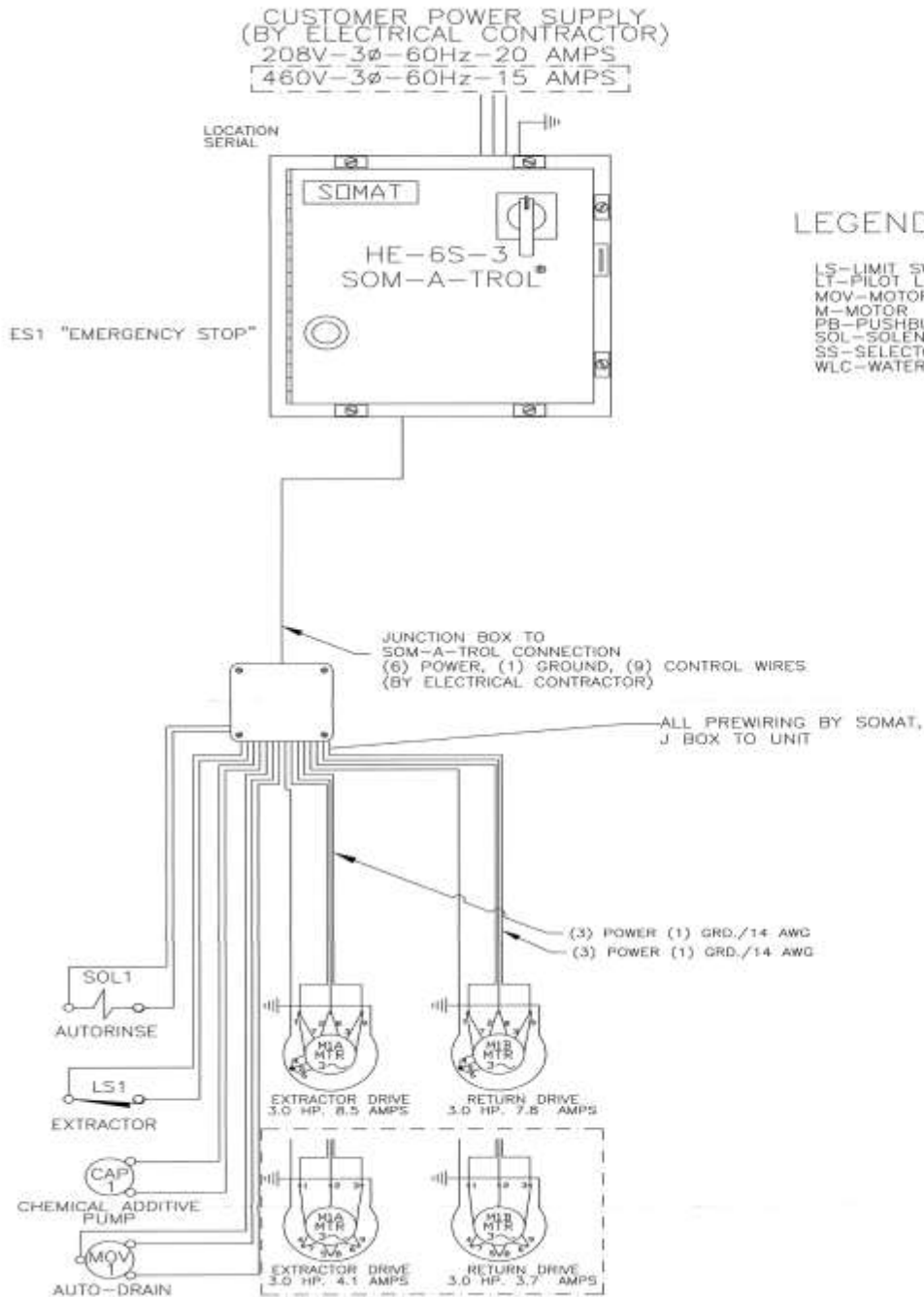

LEGEND

LS-LIMIT SWITCH
LT-PILOT LIGHT (L.E.D.)
MOV-MOTORIZED VALVE
M-MOTOR
PB-PUSHBUTTON
SOL-SOLENOID VALVE
SS-SELECTOR SWITCH
WLC-WATER LEVEL CONTROL

WIRE SIZING GUIDE		
DEVICE	WIRE SIZE	TYPE
SOM-A-TROL CONTROL LOGIC (LIMIT SWITCH) (SOL VALVE, ETC.)	18 AWG	THW-75°C
3HP RETURN PUMP MOTOR @ 480V	14 AWG	THW-75°C
3HP EXTRTR DRIVE MOTOR @ 480V	14 AWG	THW-75°C

USE NEXT SIZE AWG FOR RUNS OVER 150 FEET (46 METERS)

WIRE SIZING GUIDE		
DEVICE	WIRE SIZE	TYPE
SOM-A-TROL CONTROL LOGIC (LIMIT SWITCH) (SOL VALVE, ETC.)	18 AWG	THW-75°C
3HP RETURN PUMP MOTOR @ 480V	14 AWG	THW-75°C
3HP EXTRTR DRIVE MOTOR @ 480V	14 AWG	THW-75°C

USE NEXT SIZE AWG FOR RUNS OVER 150 FEET (46 METERS)

Other Utility Requirements

Fresh water: 4 gpm @ 45 psig, 1/2" NPT (approximate usage 40 gallons/cycle).
Drain: 4" minimum floor sink, with stainless steel removable basket recommended.