

AVSERIES

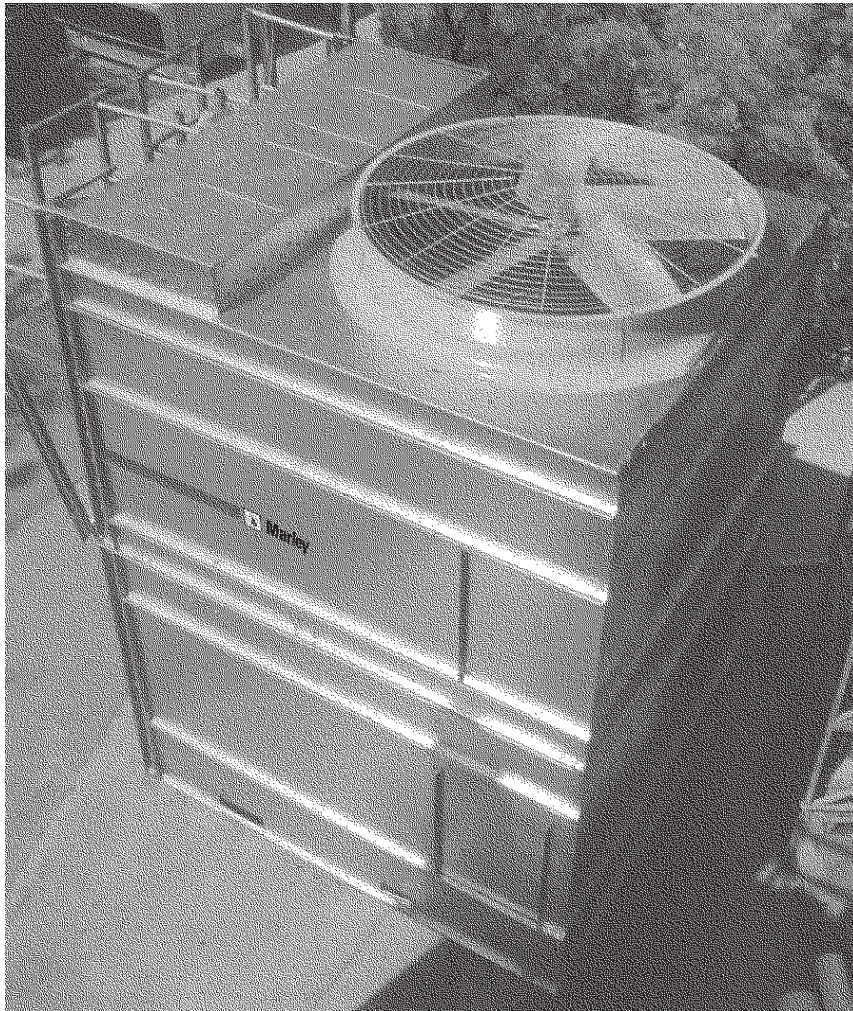

Cooling Tower Specifications



Contents

	Subject	Page
Base	Intent _____	3
	Base _____	4
	Thermal Performance _____	5
	Performance Warranty _____	5
	Design Loading _____	5
	Construction _____	6
	Mechanical Equipment _____	7
	Fill, Louvers and Drift Eliminators _____	8
	Hot Water Distribution System _____	9
	Casing, Fan Deck and Fan Cylinder _____	9
	Access _____	10
Cold Water Collection Basin _____	10	
Options	Control Options	
	Control System _____	11
	Vibration Limit Switch _____	11
	Basin Heater _____	12
	Convenience and Safety Options	
	Hot Water Basin Access Platform _____	13
	Ladder Extension _____	13
	Ladder Safety Cage _____	13
	Mechanical Equipment Access Platform _____	14
	Miscellaneous Options	
	Fan Cylinder Extensions _____	15
Equalizer Flume Weir Gate _____	15	
Marley Flow Control Valve _____	15	
Low Noise Tower _____	16	

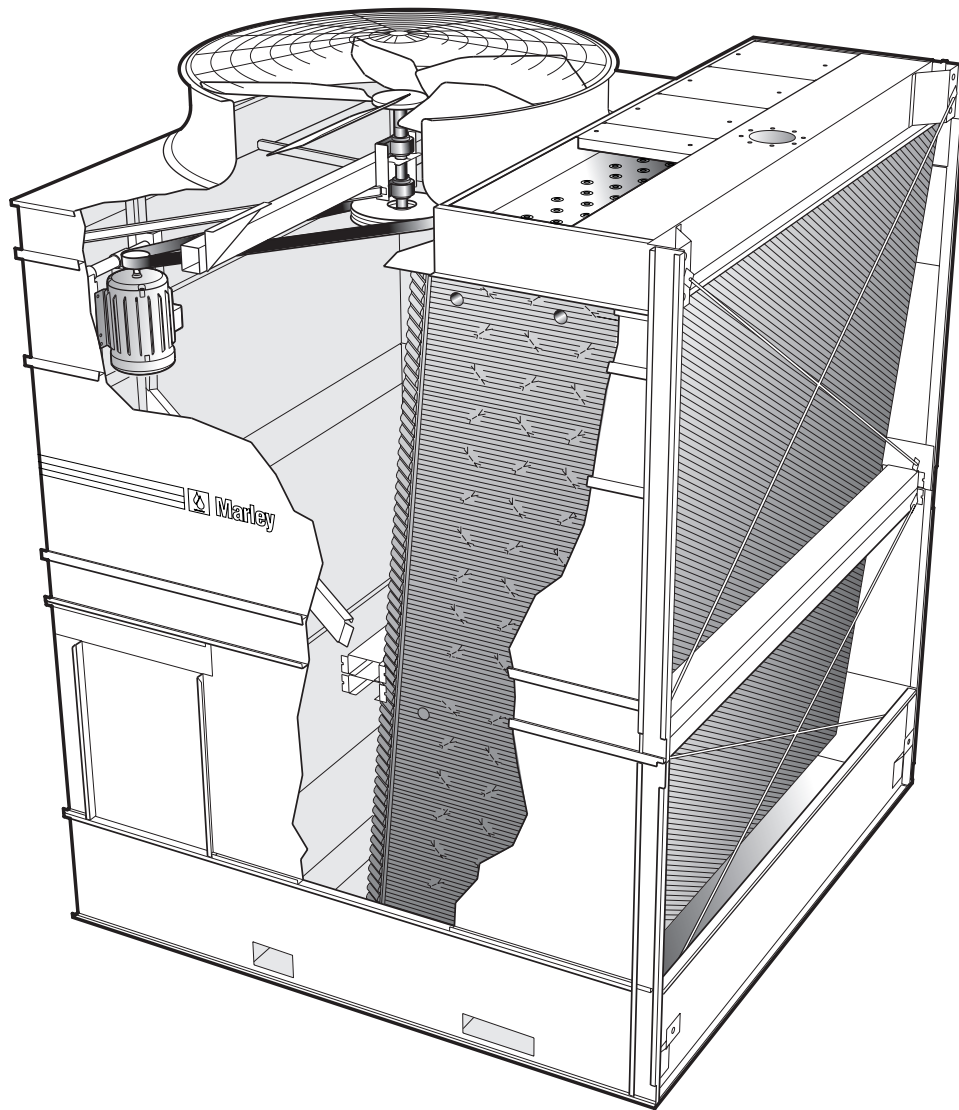

AV Series towers are galvanized steel, factory-assembled, general purpose crossflow cooling towers, designed to serve normal air conditioning and refrigeration systems as well as light industrial loads. They evolve from a singleflow concept of towers pioneered by Marley in the 1950's, and incorporate all of the design advancements that our customers have found valuable. They represent the current state of the art in this cooling tower category.

This booklet not only relates the language to use in describing an appropriate AV Series cooling tower—but also defines why certain items and features are important enough to specify with the intention of insisting upon compliance by all bidders. The left hand column of pages 4 thru 16 provides appropriate text for the various specification paragraphs, whereas the right hand column comments on the meaning of the subject matter and explains its value.

Pages 4 thru 10 indicate those paragraphs which will result in the purchase of a basic cooling tower—one that accomplishes the specified thermal performance, but which will lack many operation—and maintenance-enhancing accessories and features that are usually desired by those people who are responsible for the continued and continuing operation of the system of which the tower is part. It will also incorporate those standard materials which testing and experience has proven to provide acceptable longevity in normal operating conditions.

Pages 11 thru 16 provide paragraphs intended to add those features, components, and materials that will customize the tower to meet the user's requirements.

Marley AV Series Cooling Tower

Specifications

1.0 Base:

1.1 Provide an induced draft, crossflow type, factory assembled, film fill, industrial duty, galvanized steel cooling tower situated as shown on the plans. The limiting overall dimensions of the tower shall be _____ wide, _____ long, and _____ high to the top of the fan guard. Total operating horsepower of all fans shall not exceed _____ hp, consisting of _____ @ _____ hp motor(s). Tower shall be similar and equal in all respects to Marley Model _____.

Specification Value

□ □ □

Your specification base establishes the type, configuration, base material, and physical limitations of the cooling tower to be quoted. During the planning and layout stages of your project, you will have focused your attention on a cooling tower selection that fits your space allotment, and whose power usage is acceptable. Limitations on physical size and total operating horsepower avoid the introduction of unforeseen operational and site-related influences. Specifying the number of cells, and the maximum fan hp/cell will work to your advantage.

The benefit of crossflow towers is that they are inherently easy to operate, access, and maintain. Unlike counterflow towers, they have a spacious, full height plenum for easy access to all of the tower's internal components, and the water distribution system is readily open to view and cleaning.

If your preference is for a stainless steel tower, or if your water or air quality suggests that the use of stainless steel is prudent, change "galvanized steel" to "stainless steel" in paragraph 1.1.

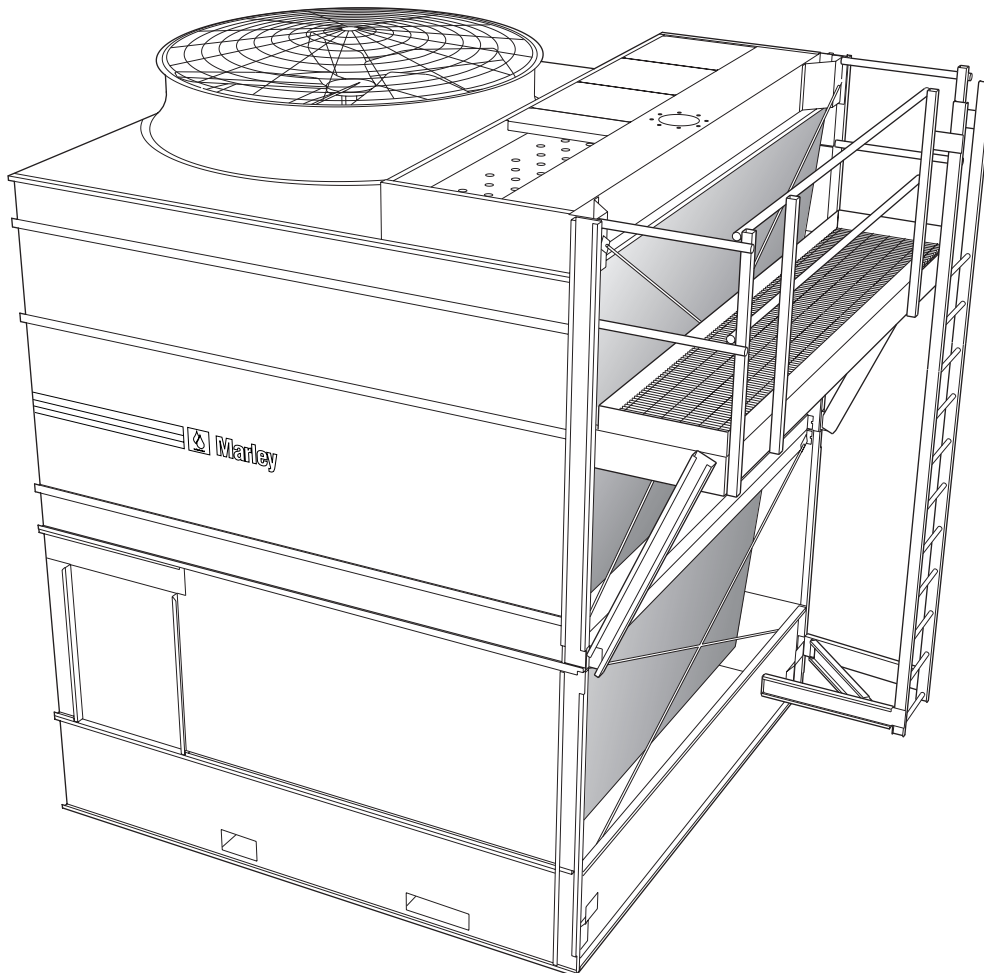

Ladder and access platform are optional accessories. See Page 13 for specification wording.

The ladder can be located on either end of the platform by simple field rearrangement of handrails and posts.

Marley AV Series Cooling Tower

Specifications

2.0 Thermal Performance:

2.1 The tower shall be capable of cooling _____ GPM (L/s) of water from _____ °F(°C) to _____ °F(°C) at a design entering air wet-bulb temperature of _____ °F(°C), and its thermal rating shall be Certified by the Cooling Tower Institute.

3.0 Performance Warranty:

3.1 CTI Certification notwithstanding, the cooling tower manufacturer shall guarantee that the tower supplied will meet the specified performance conditions when the tower is installed according to Plans. If, because of a suspected thermal performance deficiency, the Owner chooses to conduct an on-site thermal performance test under the supervision of a qualified, disinterested third party in accordance with CTI or ASME standards during the first year of operation; and if the tower fails to perform within the limits of test tolerance; then the cooling tower manufacturer will pay for the cost of the test and will make such corrections as are appropriate and agreeable to the Owner to compensate for the performance deficiency.

4.0 Design Loading:

4.1 The tower structure and anchorage shall be designed to withstand a wind load of 20 psf (957 Pa), as well as .3g seismic load while operating. The tower shall be designed to withstand shipping and hoisting loads of 2g horizontal and 3g vertical. Handrails, where specified, shall be capable of withstanding a 200 lb. (890 N) concentrated live load in any direction, and shall be designed in accordance with OSHA guidelines. Fork lift slots shall be provided in the basin side supports to allow handling of the tower at grade level.

Specification Value

□ □ □
CTI Certification means that the tower has been tested under operating conditions and found to perform as rated by the manufacturer under those circumstances. It assures the buyer that the tower is not **intentionally or inadvertently** undersized by the manufacturer.



□ □ □
However, CTI certification alone is not sufficient to assure you that the tower will perform satisfactorily in your situation. Certification is established under relatively controlled conditions, and towers seldom operate under such ideal circumstances. They are affected by nearby structures, machinery, enclosures, effluent from other towers, etc. Responsible and knowledgeable bidders will take such site-specific effects into consideration in selecting the tower—but the specifier must **insist** by the written specification that the designer/manufacturer guarantee this “real world” performance. Any reluctance on the part of the bidder should cause you some concern.

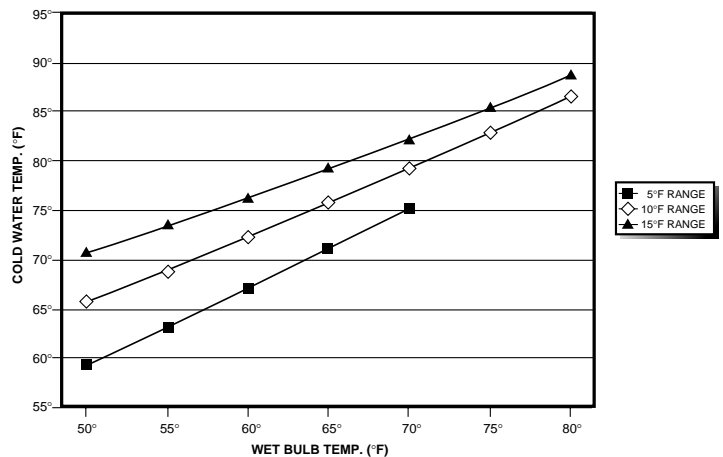

□ □ □
The design wind and seismic loads at the left are the minimum allowables for any model in the line under accepted design standards. Some models can withstand greater loads as listed below:

Model	Wind	Seismic
AV61 and AV62	30 psf (1436 Pa)	.7g
AV63 thru AV65	20 psf (957 Pa)	.3g
AV66 and AV67	20 psf (957 Pa)	.46g

If your application requires higher loads, consult your Marley sales representative. These standards give you assurance that the tower can be shipped, handled, hoisted and ultimately operated in a normal cooling tower environment.

Marley AV Series Cooling Tower

Specifications

5.0 Construction:

5.1 Except where otherwise specified, all components of the cooling tower shall be fabricated of heavy-gauge steel, protected against corrosion by G-235 galvanizing. The tower shall be capable of withstanding water having a pH of 6.5 to 8.0; a chloride content (NaCl) up to 500 ppm; a sulfate content (SO₄) up to 250 ppm; a calcium content (CaCO₃) up to 500 ppm; silica (SiO₂) up to 150 ppm; and design hot water temperatures up to 125°F (51.7°C). The circulating water shall contain no oil, grease, fatty acids, or organic solvents.

5.2 The specifications, as written, are intended to indicate those materials that will be capable of withstanding the above water quality in continuing service, as well as the loads described in paragraph 4.1. They are to be regarded as minimum requirements. Where component materials peculiar to individual tower designs are not specified, the manufacturers shall take the above water quality and load carrying capabilities into account in the selection of their materials of manufacture.

Specification Value

□ □ □

In the history of cooling towers, no other coating for carbon steel has exhibited the success and longevity of galvanization in exposure to the normal cooling tower water quality defined at left. No paints or electrostatically applied coatings, however exotic they may be, can approach galvanization's history of success.

Except for those unusual operating situations where the circulating water may be so laden with suspended solids, algae, fatty acids, product fibers, active organisms reflected in BOD, and the like that plugging of the fill is a probability, reasonable attention to the construction materials and/or their coatings is all that is normally required.

If your preference is for a stainless steel tower, or if your water or air quality suggests that the use of stainless steel is prudent, change "heavy gauge steel, protected against corrosion by G-235 galvanizing" to "heavy gauge stainless steel" in paragraph 5.1.

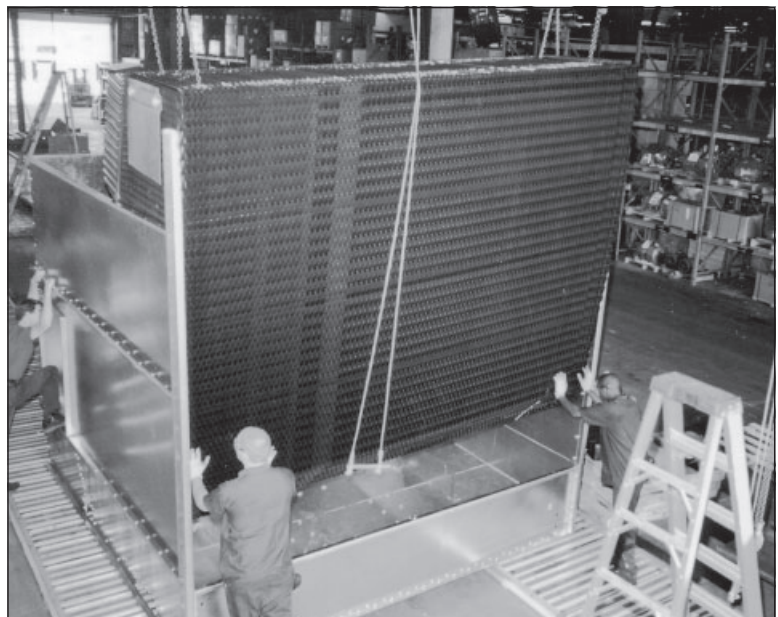

Factory Assembly

Marley AV Series Cooling Tower

Specifications

6.0 Mechanical Equipment:

6.1 Fan(s) shall be propeller type, incorporating heavy duty aluminum alloy blades and electrogalvanized hubs. Blades shall be attached to hubs with stainless steel hardware, and shall be individually adjustable. Fan(s) shall be driven through an industrial grade system of V-belts, pulleys, and tapered roller bearings. Bearings shall be rated at 50,000 hours, or greater.

6.2 Motor(s) shall be ____ hp maximum, Totally Enclosed, 1.15 service factor, variable torque, and specially insulated for cooling tower duty. Speed and electrical characteristics shall be _____ RPM, single-winding, ___ phase, _____ hertz, ____ volts.

6.3 The fan and fan drive assembly for each cell shall be supported by a rigid, welded, hot dip galvanized steel structural support that resists misalignment. The mechanical equipment assembly shall be warranted against any failure caused by defects in materials and workmanship for no less than five (5) years following the date of tower shipment. This warranty is limited to the fan, fan shaft, bearings, and mechanical equipment support. The motor, motor components, sheaves and belt(s) are warranted by their manufacturer.

Specification Value

□ □ □

Propeller-type fans require only half the operating hp of blower-type fans. However, they should be readily adjustable to permit compensation for jobsite conditions that may tend to overload the motor. The fans of one manufacturer require the **purchase** of special positioners for each increment of fan blade pitch.

Unless otherwise specified, motor speed will be 1800 RPM in 60 Hertz areas and 1500 RPM in 50 Hertz areas. If you prefer the operating flexibility of two-speed operation, please specify the RPM to be 1800/900 (1500/750 in 50 Hertz regions). Incidentally, two speed motors are a far better choice than separate "pony" motors which simply double the problems indicated above.

If your preference is for a stainless steel tower, or if your water or air quality suggests that the use of stainless steel is prudent, change "hot dip galvanized steel" to "stainless steel" in paragraph 6.3.

Marley AV Series Cooling Tower

Specifications

7.0 Fill, Louvers and Drift Eliminators:

7.1 Fill shall be film-type, thermoformed of 15 mil (0.38 mm) thick PVC, with louvers formed as part of each fill sheet. Fill shall be suspended from hot-dip galvanized structural tubing supported from the tower structure, and shall be elevated above the floor of the cold water basin to facilitate cleaning. The air inlet face of the tower shall be free of water splash-out.

7.2 Drift eliminators shall be PVC, triple-pass, and shall limit drift losses to no more than 0.005% of the design GPM flow rate.

Specification Value

□ □ □

Louvers integral with the fill keep the flowing water within the confines of the fill. The separate external louvers used by others permit water to escape the fill and form ice or produce an unsightly situation adjacent to the tower. If you plan to use your tower in the wintertime, particularly for free cooling, integral louvers will put your operating concerns to rest.

Drift rate varies with design water loading and air rate, as well as drift eliminator depth and number of directional changes. The indicated rate of 0.005% is easily achievable without premium cost. If a lower rate is required, please discuss with your Marley office or representative.

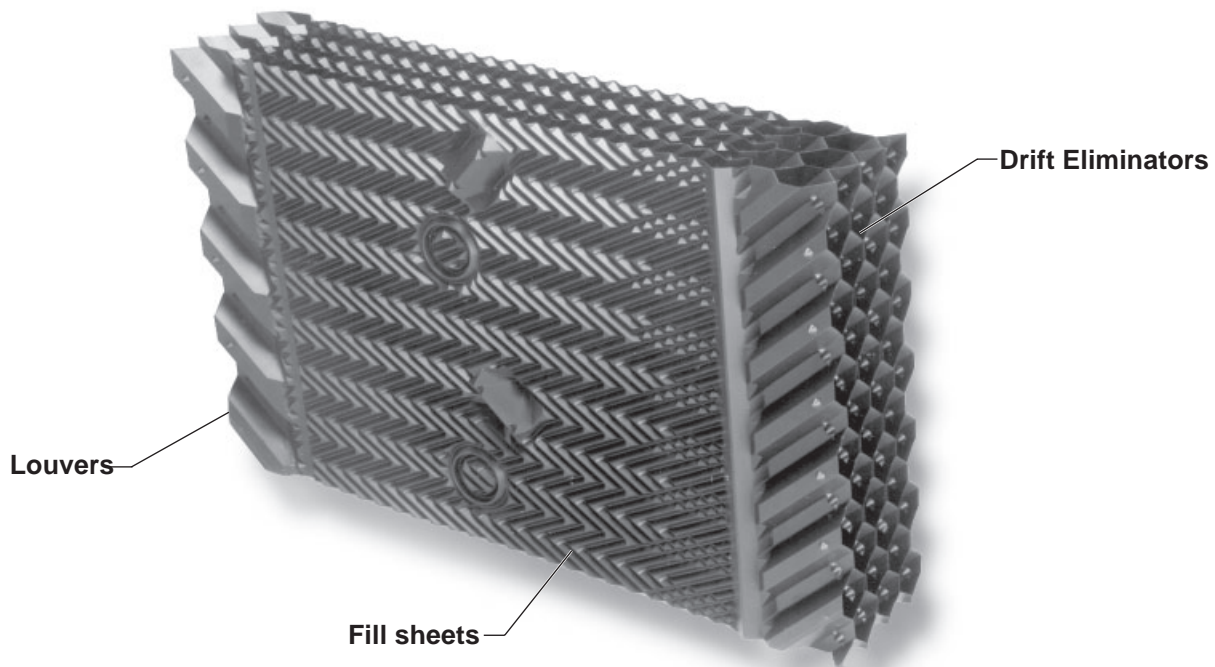
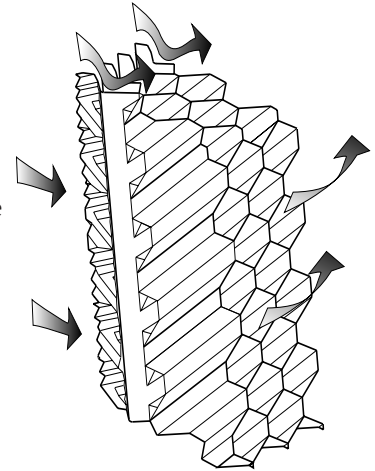

Marley AV Series Cooling Tower

Specifications

8.0 Hot Water Distribution System:

8.1 An open basin above the bank of fill shall receive hot water piped to each cell of the tower. These distribution basins shall be installed and sealed at the factory, and shall be equipped with removable, galvanized steel covers to keep out leaves and debris, and to retard the growth of algae.

8.2 Each basin shall include an inlet hole and bolt circle to accept a 125# flange connection per ANSI B16.1. Removable, interchangeable polypropylene nozzles installed in the floor of these basins shall provide full coverage of the fill by gravity flow.

9.0 Casing, Fan Deck, and Fan Cylinder:

9.1 The casing and fan deck shall be heavy-gauge galvanized steel, and shall be capable of withstanding the loads described in paragraph 4.1. The fan cylinder shall be molded FRP, and shall be through-bolted to the fan deck to provide a consistently stable operating shroud for the fan. The top of the fan cylinder shall be equipped with a conical, non-sagging, removable fan guard, fabricated of welded 5/16" and 7 gauge rods, and hot-dip galvanized after fabrication.

Specification Value

□ □ □

Gravity-flow distribution basins are a feature of crossflow type towers, resulting in operating pump heads of from 10 to 20 feet less than that encountered in counterflow towers with pressurized spray systems. Also, these basins are out where they can be easily inspected—even maintained—while the tower is in operation. Spray systems of counterflow towers, sandwiched between the top of the fill and the drift eliminators, are extremely awkward to access and maintain.

If your preference is for a stainless steel tower, or if your water or air quality suggests that the use of stainless steel is prudent, change "galvanized steel" to "stainless steel" in paragraph 8.1.

□ □ □

If your preference is for a stainless steel tower, or if your water or air quality suggests that the use of stainless steel is prudent, change "galvanized steel" to "stainless steel" in the first sentence of paragraph 9.1. The heavy gauge fan guard remains galvanized steel.

Marley AV Series Cooling Tower

Specifications

Specification Value

10.0 Access:

10.1 Large galvanized steel access doors 30" (762 mm) wide and a minimum of 42" (1067 mm) high shall be located in both endwalls for entry into the cold water basin and fan plenum area. Access doors shall be operable from inside as well as outside the tower.

□ □ □

The access doors on competitive towers may be 18" (457 mm) wide or smaller, which is unreasonably small for a human being. Specifying the size of the door will cause those bidders to take exception, alerting you to a potential maintenance headache. Two doors are standard on all towers so that access between cells of multicell towers is assured.



If your preference is for a stainless steel tower, or if your water or air quality suggests that the use of stainless steel is prudent, change "galvanized steel" to "stainless steel" in paragraph 10.1.

11.0 Cold Water Collection Basin:

11.1 The cold water basin shall be heavy-gauge galvanized steel, and shall include the number and type of suction connections required to accommodate the out-flow piping system shown on the Plans. Suction connections shall be equipped with galvanized debris screens. A factory-installed, float-operated, mechanical makeup valve shall be included. A 3" (76.2 mm) diameter drain and a 4" (101.7 mm) diameter overflow shall be provided in each cell of the tower. The basin shall include a depressed section into which accumulated silt can be flushed to permit cleaning. The basin floor adjacent to the depressed section shall slope toward the depressed section to prevent buildup of silt under the fill area. Towers of more than one cell shall include flumes for flow and equalization between cells.

□ □ □

Marley offers your choice of side suction and bottom outlets to accommodate a significant variety of piping schemes. Unless so specified, the tower you may be asked to approve may only be available with one type of suction connection, requiring you to redesign your piping layout.

If your preference is for a stainless steel tower, or if your water or air quality suggests that the use of stainless steel is prudent, change "galvanized" to "stainless" in paragraph 11.1.

Options

Specifications

Control Options

Control System:

Para. 6.4: Add the following paragraph in the Mechanical Equipment section:

Each cell of the cooling tower shall be equipped with a UL listed control system in a NEMA 3R or 4X outdoor enclosure capable of controlling single-speed or two-speed motors as required, and designed specifically for cooling tower applications. The panel shall include a main fused disconnect with an external operating handle, lockable in the off position for safety. Across-the-line magnetic starters or solid state soft-start starters as required shall be controlled with a thermostatic or solid state temperature controller. Door mounted selector switches shall be provided to enable automatic or manual control and wired for 120VAC control. Control circuit to be wired out to terminal blocks for field connection to a remote vibration switch and for access to extra 120VAC 50VA control power, overload trip alarms and remote temperature control devices. The temperature controller shall be adjustable for the required cold water temperature. If a thermostatic controller is used it shall be mounted on the side of the tower with the temperature sensing bulb installed in the cold water basin using a suspension mounting bracket. If a solid state temperature controller is used the controller will be door mounted on the control panel. The temperature controller will display two temperatures, one for outgoing water and the other for set point. Water temperature input shall be obtained using a three-wire RTD with dry well in the outlet water piping and wired back to the solid state temperature controller in the control panel.

Specification Value

□ □ □

If it is your opinion that the control system for the cooling tower should be part of the tower manufacturer's responsibility, we are in wholehearted agreement with you. Who better to determine the most efficient mode and manner of a tower's operation—and to apply a system most compatible with it—than the designer and manufacturer of the cooling tower?

Options

Specifications

Vibration Limit Switch:

Para. 6.5: Add the following paragraph in the Mechanical Equipment section: A single-pole, double-throw vibration limit switch in a NEMA 4 housing shall be installed on the mechanical equipment support for wiring into the owner's control panel. The purpose of this switch will be to interrupt power to the motor in the event of excessive vibration. It shall be adjustable for sensitivity, and shall require manual reset.

Control Options

Basin Heaters:

Para. 11.2: Add the following paragraph in the Cold Water Basin section: Provide a system of electric immersion heaters to prevent freezing of water in the collection basin during periods of shutdown. The system shall consist of one or more stainless steel electric immersion heaters installed in threaded couplings provided in the side of the basin. A NEMA 4 enclosure shall house a magnetic contactor to energize heaters; a transformer to provide 24 volt control circuit power; and a solid state circuit board for temperature and low water cutoff. A control probe shall be located in the basin to monitor water level and temperature. The system shall be capable of maintaining 40°F (4.4°C) water temperature at an ambient air temperature of ___ °F (___ °C).

Specification Value

□ □ □

Unless specified otherwise, a Metrix switch will be provided. A double-pole, double-throw model is also available. If purchased in conjunction with the Control System, it is also factory-wired. The requirement for manual reset assures that the tower will be visited to determine the **cause** of excess vibration.

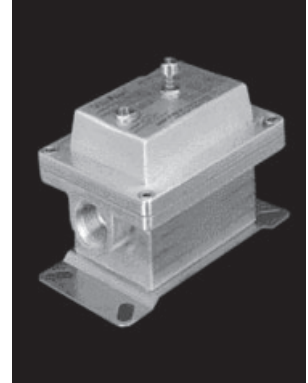

□ □ □

The basin heater components described at left represent Marley's recommendation for a reliable automatic system for the prevention of basin freezing. They are normally shipped separately for installation at the jobsite by the installing contractor. When purchased in conjunction with the enhanced Control System option, however, they are customarily factory-mounted and tested.

Submerged in basin water, in which zinc ions are present, copper immersion heaters must not be used. Insist upon stainless steel.

The ambient air temperature that you fill in should be the lowest 1% level of winter temperature prevalent at site.

Ask for appropriate Marley drawing.

Options

Specifications

Convenience and Safety Options

Hot Water Basin Access Platform:

Para. 10.2: Add the following paragraph in the Access section: Provide an external platform near the top of the louver face for access to the hot water distribution system. The platform shall be galvanized steel bar grating, supported by galvanized steel framework attached to the tower. The platform shall be surrounded by a handrail, kneerail, and toeboard. A permanently attached 1'-6" (457.2 mm) wide aluminum ladder with 3" (76.2 mm) I-beam side rails and 1.25" (31.8 mm) diameter serrated rungs shall extend from the base of the tower to the top of the handrail.

Ladder Extension:

Para. 10.2: Add the following to the end of the Hot Water Basin Access Platform paragraph: Provide a ladder extension for connection to the foot of the external ladder. This extension shall be long enough to rise from the roof (grade) level. The installing contractor shall be responsible for cutting the ladder to length; attaching it to the foot of the tower ladder; and anchoring it at its base.

Ladder Safety Cage:

Para. 10.2: Add the following to the end of the Hot Water Basin Access Platform paragraph: A heavy gauge galvanized steel safety cage shall surround the ladder, extending from a point 7'-0" (2134 mm) to 8'-0" (2439mm) above the foot of the ladder to the top of the distribution basin access platform handrail.

Specification Value

□ □ □

Periodic inspection and maintenance of a cooling tower distribution system is fundamental to preserving maximum cooling system efficiency. All cooling towers—crossflow or counterflow—are subject to clogging to varying degrees by waterborne contaminants such as pipe scale and sediment. Therefore, safe and easy access to these components is of significant value to the operator.



Access can be provided in a number of ways, including portable ladders or scaffolding, but for maximum safety and convenience, Marley offers a factory installed access platform with guardrails to make this task as safe and user-friendly as possible. Further, its location on the side of the tower does not add to the height of the unit, preserving architectural integrity. See graphic, Page 4. It also saves the owner time and money, in that maintenance personnel may devote their time to inspection rather than searching for ladders or erection of portable scaffolding.

□ □ □

Many towers are installed such that the base of the tower is 2'-0" (609.6 mm) or more above the roof or grade level. This makes it difficult to get up to the foot of the attached ladder. The ladder extension alleviates this problem. Marley ladder extensions are available in standard 5'-0" (1.524 m) and 11'-0" (3.353 m) lengths.

□ □ □

To meet OSHA guidelines, towers whose distribution basin access platforms are 20'-0" (6.096 m) or more above roof or grade, and which are equipped with external ladders, should have safety cages surrounding the ladders.

Options

Specifications

Mechanical Equipment Access Platform:

available only on AV63000 models and larger

Para. 10.3: Add the following paragraph in the Access section: Provide an internal platform approximately 7' (2134 mm) below the level of the fan for access to the mechanical equipment. The platform shall be galvanized steel bar grating, supported by galvanized steel framework attached to the tower. The platform shall be surrounded by a handrail and kneerail. A permanently attached 1'-6" (457.2 mm) wide aluminum ladder with 3" (76.2 mm) I-beam side rails and 1.25" (31.8 mm) diameter serrated rungs shall extend from the cold water basin to the top of the handrail.

Specification Value

□ □ □

Periodic inspection and maintenance of cooling tower fans, motors and other rotating equipment is fundamental to preserving maximum cooling system efficiency. All mechanical draft cooling towers—forced or induced draft—are subject to vibration and wear. Therefore, safe and easy access to these components for inspection and maintenance is of significant value to the operator.

Access can be provided in a number of ways, including portable ladders or scaffolding, but for maximum safety and convenience, Marley offers a factory installed access platform with guardrails to make this task as safe and user-friendly as possible. See graphic below. It also saves the owner time and money, in that maintenance personnel may devote their time to inspection rather than searching for ladders or erection of portable scaffolding.

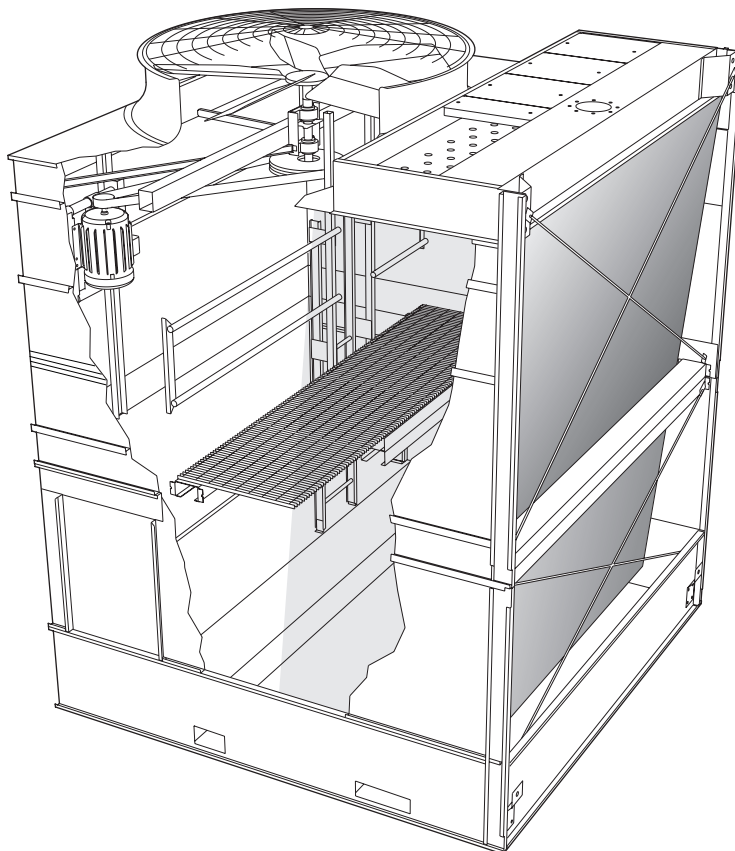

Options

Specifications

Miscellaneous Options

Fan Cylinder Extensions:

Para. 9.1: Insert the following after the first sentence: Fan cylinder extensions shall be provided to elevate the fan discharge to a height of ___ ft. (___ m) above the top of the standard fan cylinder.

Equalizer Flume Weir Gates:

Para. 11.2: Add the following paragraph under Cold Water Collection Basin: The interconnecting flume between cells shall be equipped with a removable cover plate to permit the shutdown of one cell for maintenance purposes, or to permit independent cell operation.

Marley Flow Control Valve:

Para. 8.3: Add the following paragraph under Hot Water Distribution System: A heavy-duty, industrial grade flow-control valve shall be provided at the inlet to the hot water basin. The valve shall permit both flow balancing on multicell towers and temporary shut-off for maintenance of selected cells. Valve shall have a machined cast iron body, with stainless steel operating stem, and heavy-duty locking handle.

Specification Value

□□□

Extensions are available in 11 ¾" (298.5 mm) increments to a maximum extension height of 6'-10 ¼". Such extensions may be considered necessary in order to elevate the discharge beyond the bounds of an enclosure. Discuss applicability with your local Marley sales representative.

□□□

Where it is your intention to be able to operate other cells of the tower while the flume cover plate is installed, separate outlet connections, float valves, and overflows *must* be provided for each cell. Likewise, this would require separate sensors and controls for basin heater systems, if installed.



Options

Specifications

Specification Value

Low Noise Tower:

Para. 1.2: Add the following paragraph under Base: The cooling tower shall be quiet operating, and shall produce an overall level of sound no higher than ____ dBA, measured at the critical location indicated on the Plans.

□ □ □

Sound produced by a AV Series tower operating in an unobstructed environment will meet all but the most restrictive noise limitations—and will react favorably to natural attenuation. Where the tower has been sized to operate within an enclosure, the enclosure itself will have a damping effect on sound. Sound also declines with distance—by about 5 or 6 dBA each time the distance doubles. Where noise at a critical point is likely to exceed an acceptable limit, you have several options—listed below in ascending order of cost impact:

- Where only a slight reduction in noise will satisfy—and the source of concern is in a particular direction—merely turning the tower may be the answer. Less sound emanates from the cased face of the tower than does from the air intake face.
- In many cases, noise concerns are limited to nighttime, when ambient noise levels are lower and neighbors are trying to sleep. You can usually resolve these situations by using two-speed motors in 1800/900 configuration; and operating the fans at half-speed **without cycling** “after hours”. (The natural nighttime reduction in wet-bulb temperature makes this a very feasible solution in most areas of the world, but the need to avoid cycling may cause the cold water temperature to vary significantly.)
- Where noise is a concern at all times (for example, near a hospital), the best solution is to oversize the tower so it can operate continuously at half (900 RPM) motor speed even at the highest design wet-bulb temperature. A typical sound reduction is 10 dBA at 1/2 fan speed, but larger reductions are often possible.
- Extreme cases may require special fans or inlet and discharge sound attenuator sections; however, the static pressure loss imposed by attenuators may necessitate an increase in tower size. This is the least desirable approach because of the significant cost impact—and because of the obstruction to normal maintenance procedures.

Your Marley office or representative can help you meet your sound requirements.



7401 W 129 Street • Overland Park, KS 66213 • 800 462 7539

www.marleyct.com • email: info@marleyct.spx.com

In the interest of technological progress, all products are subject to design and/or material change without notice.

©2003 Marley Cooling Technologies, Inc

Printed in USA

SPEC AV-03