

ChemPump G Series Canned Motor Pump 50 gpm

Mfg: ChemPump

Model: GVBS-5K-1S

Stock No. OIP019.

Serial No.

ChemPump G Series Stainless Steel Canned Motor Pump 50 gpm.

Model GVBS-5K-1S. 316 stainless steel pump case and impeller. 84 head ft., 3 in. inlet, 1-1/2 in. outlet, Imp. Dia: 5-1/4 in. Totally Enclosed Motor, 7.9 hp, 3,450 rpm, 230/460 V, 17.6/8.8 amps. Full Load: 5.9 KW, 3 phase, class H, S/N 29475-1. Overall Dimensions: 26 in. L x 10 in. W x 17 in. H. These seal less pumps feature automatic hydraulic thrust balance, replaceable thrust surface design, direction of rotation indicator and precision front and rear bearings. Cost new \$8,265.



PUMP CASING D-38201	SIZE 3 x 1 1/2 x 6 1/4	MODEL GVBS(T)
IMPELLER C-24463	IMP. DIA.	RPM 3450
SERIAL #	REVISION DATED 9/92: COMPUTER GENERATED	

Curves are based on shop test while handling clean water at 20°C and at sea level. Performance guarantees apply at rating point only. Efficiencies shown are overall wire to water. Numbers beneath model designations indicate full load kilowatt ratings for the referenced motor load lines. When pumping fluids with specific gravities other than 1.0, select pump model (see load line) to handle load equivalent in feet of water. e.g. 40 feet of fluid of Sp. Gr.=1.5 is load equivalent of 60 feet (1.5x40) of water. Please note that this is merely a short cut method to estimate the model required. For proper model selection, especially when handling a fluid with a Sp. Gr. greater than 1.7, consult your Chempump representative or the factory.

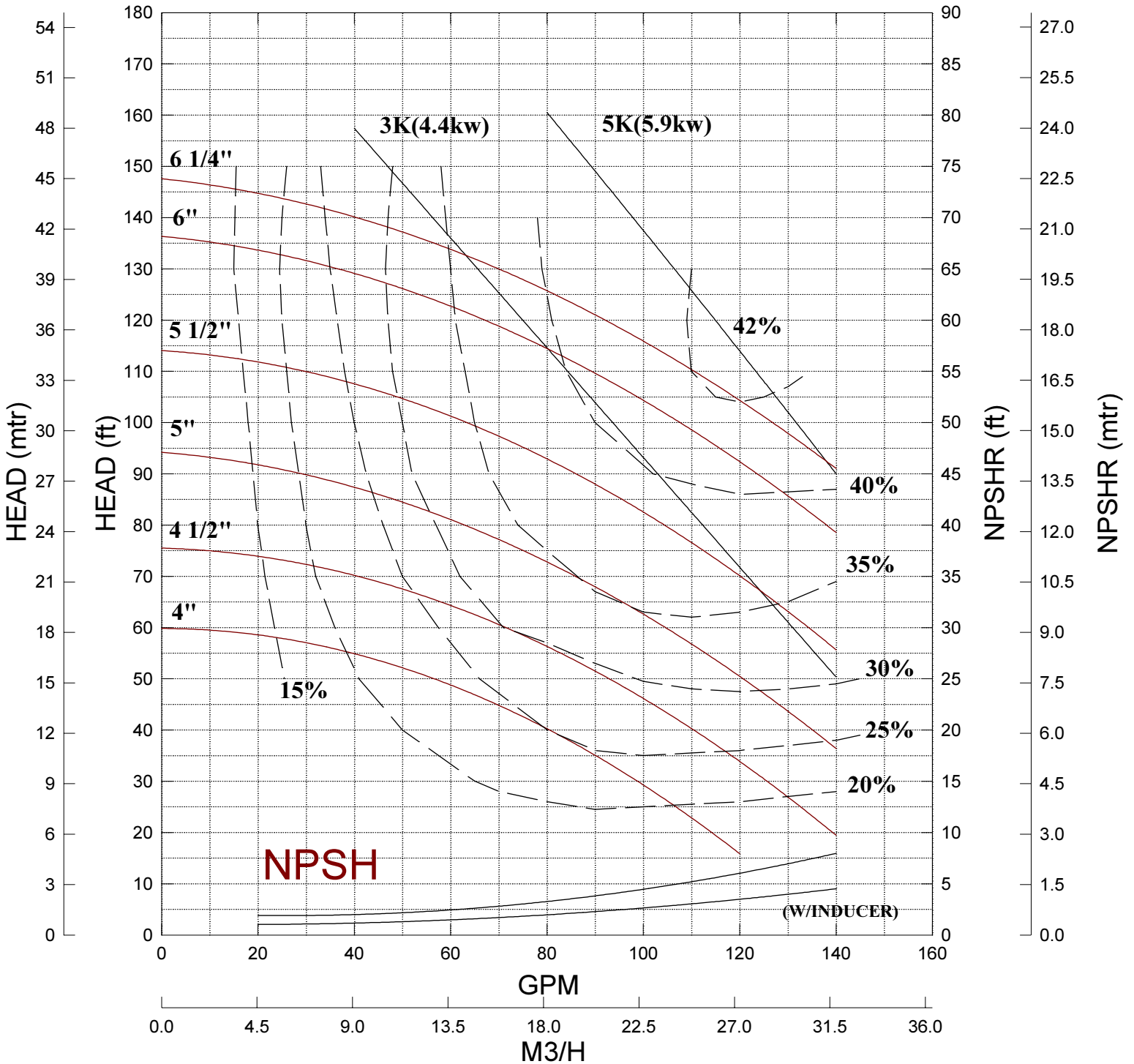

CRANE	CHEMPUMP DIVISION CRANE CO. WARRINGTON, PENNSYLVANIA	DRAWN WF	DATE 11-18-86	CURVE A-70066	REV. 2

Chempump Canned Motor Pumps

1. Impeller
2. Bearings
3. Motor Windings
4. Circulation Tube
5. Sealless Junction Box
6. Thrust Surfaces
7. Circulation Filter
8. Stator Cavity
(Oil-filled, dry or solid-filled)
9. Rotor
10. Rotation Indicator

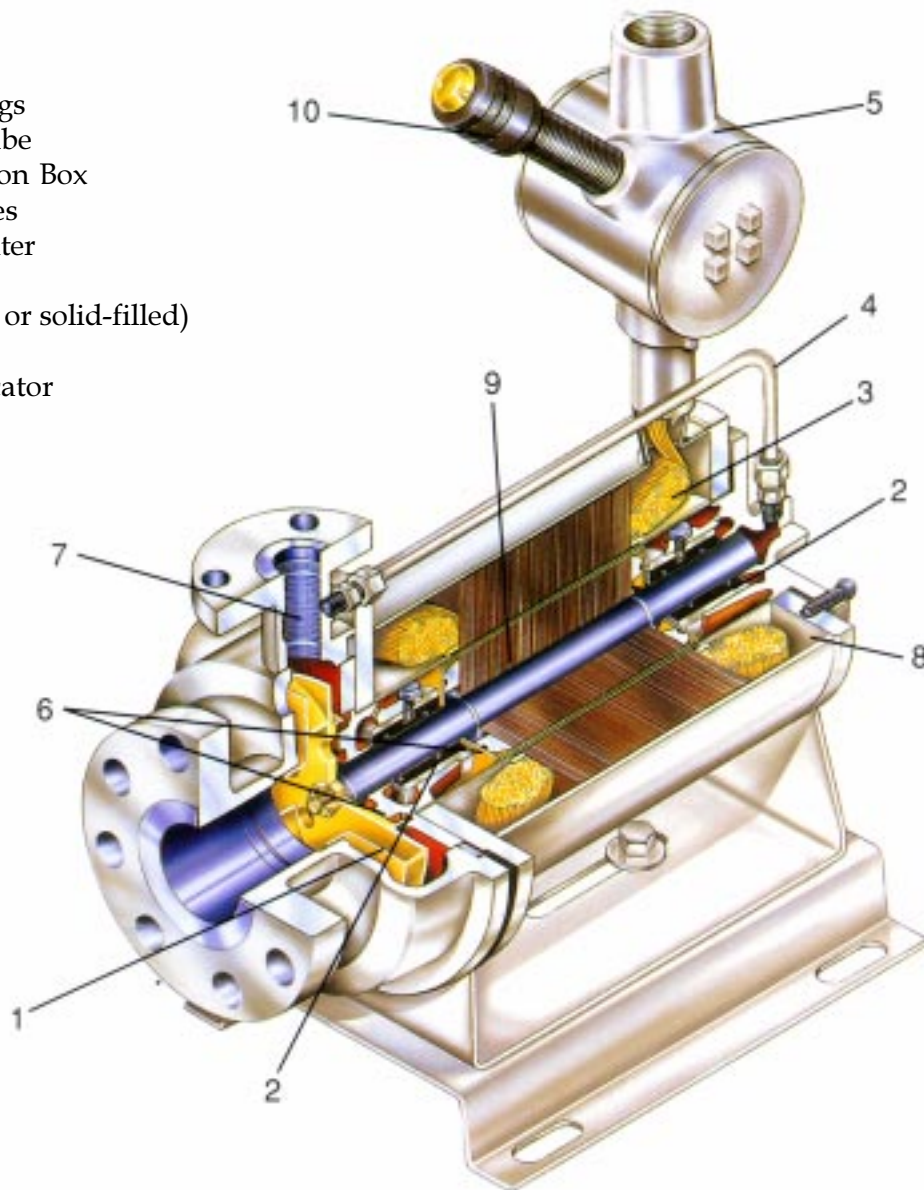

Exceptional Fugitive Emissions Containment

Chempump introduced the first hermetically sealed pump and motor design over 40 years ago. And we've been improving it ever since. That's why "specify Chempump" has become an industry standard specification for sealless canned motor pumps.

The G Series centrifugal pump is designed as a single sealless unit that has no stuffing box, no seals, no packing. Pumped fluids cannot leak out or be contaminated by in-leakage. No special tools, foundation, leveling or alignment are required for installation.

Choose from more than 100 models in 30 sizes from 1 to 125 HP, capacities to 2,000 GPM and fluid temperatures of -400°F to +1,000°F.

Standard Features

Automatic Thrust Balance

- An automatic thrust balance feature equalizes hydraulic pressures across the rotor and impeller, thereby controlling axial thrust.

Precision Front and Rear Bearings

- Manufactured to extremely close tolerances, Chempump bearings ensure longer life and maintenance-free operation. Bearings can be supplied in materials to suit virtually any pumped fluid.

Oil-Filled Stator Cavity

- The stator winding cavity can be filled with a dielectric oil, to greatly improve the rate of heat dissipation from the motor windings and to protect against condensation damage. This, combined with a high grade of insulation, results in a motor life expectancy that exceeds NEMA standards by a wide margin.

Built-in Thermal Cut-Out

- Motors are protected against excessive heat by a built-in thermal cutout, which must be wired into the electrical power source. If the motor windings reach a pre-set temperature limit, the pump will automatically shut down before permanent damage can occur.

Direction of Rotation Indicator

- The direction of rotation indicator is a compact addition to the electrical junction box, which illuminates to verify that the direction of rotation is correct.

Replaceable Thrust Surfaces

- All G Series pumps are fitted with easily replaceable thrust surfaces to prevent damage from axial system upsets.

Operation

The G Series pump has only one moving part -- a combined rotor and impeller assembly, which is driven by an induction motor.

A small portion of the pumped fluid is allowed to circulate through the motor section, cooling the motor and lubricating and cooling the bearings. The circulating fluid passes through a self-cleaning filter (fitted in the discharge neck of the pump casing) through the circulation tube to the rear of the pump. It then moves to the rotor cavity (where it is isolated from the motor windings by a corrosion-resistant, nonmagnetic alloy liner), across the bearings, and back into the main flow.

The discharge filter contributes to extended motor and bearing life by keeping the circulated fluid free of damaging particles. Because this filter is open at the top and bottom, it is constantly washed by the discharge flow and does not require periodic inspection.

Special Application Engineering

Submerged Service Pumps

- G Series submerged service pumps offer many advantages over convention all pumps when used in the nuclear and chemical processing industries. Modification fro submerged service is simple and economical.

Nuclear Service Pumps

- Chempump's experience in nuclear service pumps dates back to the early 1950s. G Series nuclear service pumps can be provided with the A.S.M.E. "N" Stamp, Class 1, 2 and 3, and are qualified for IEEE 323 service. Seismic qualification is available to meet all requirements for nuclear energy applications.

Slurry Service

- For fluids with suspended solids, G Series slurry pumps feature a lip seal design that prevents process fluid (which contains solid particles) from entering the motor section. As an alternative method, Chempump offers an external circulation line filter for the effective handling of fluid containing suspended solids.

Lethal Fluid Service

- Chempump can provide pumps built to paragraph UW-2 of section VIII of the ASME code. Custom-designed pumps are also available.

Canned Motor Drives

- G Series canned motor drives are used principally in agitators, mixers and similar applications that require a sealless motor. The rotor shaft is extended beyond the motor section to accommodate agitator blades.

G Series Optional Features

Bearing Wear Detector

- Inexpensive addition of new pumps or simple retrofit to pumps on-line.
- Indicates when G Series bearing require replacement.
- Helps prevent system downtime caused by pump malfunction.
- Adaptable for remote control operation.
- U.L. listed.

Sealless Junction Box

- Designed to prevent system fluid from leaking into the electrical conduit line in the event of a malfunction.
- U.L. listed.

Hardened Rotor Journals

- Corrosion-resistant, wear-resistant.
- Can extend useful life to many times that of other journals.

Pressurized Circulation System

- Self-contained.
- Improves pump's ability to handle liquids at or near their boiling (vapor pressure) points.
- Handles such liquids as ammonia, refrigerants, fluorocarbons and chlorinated hydrocarbons.

Inducers

- Developed to improve required net positive suction head (NPSH).
- Installs easily to simplify field retrofit.

Back Flush

- Used where solids are present in the pumped fluid or where fluid viscosities are high.
- Prevent solid particles from reaching the bearings.

UL-Listed Explosion-Proof Design

- Meets U.L. requirements for explosion-proof operation.
- Can be furnished with Class 1, Group D, Div. 1 or Class 1, Groups C and D, Div. 1 Certification.

High-Temperature Motor Insulation

- Chempump uses motor insulation capable of withstanding fluid temperatures of up to 650°F without cooling jackets or heat exchangers. This feature can be provided for any G Series pump.
- GT Series models can be retrofitted with high-temperature insulation to eliminate cooling water requirements.

Dry/Solid Filled Motors

- All Chempump motors are capable of operating without oil in the windings.
- Used where system contamination control or absolute secondary containment is critical.

Temperature Sensors

- Highly sensitive temperature monitoring of fluid in the rotor cavity.
- Provides shutdown in the event of abnormal rotor cavity temperatures.
- Can be used with any temperature indication device.

Heat Exchangers

- For applications that require heating or cooling of fluids before the fluid enters the rotor chamber.

Water Jackets

- Provide additional motor cooling or heating when handling of fluids at controlled temperatures.

Support Services

Chempump gives you much more than the most reliable pumps available. We offer an unprecedented record of application and engineering experience, and a commitment to providing the best aftermarket service in the business.

Our factory service centers are strategically located throughout the country for fast turnaround of your service requests.

Materials

Steel, 316 Stainless Steel and Carpenter 20 are standard materials of construction. Also available are Monel, Hastelloy B or C, and other materials, as needed.

2-Year Warranty

Based on an unprecedented application history of over 40 years, Chempump offers a 2-year warranty.

**STANDARD MATERIALS OF CONSTRUCTION
Models GA, GB, GC, GVBS, GVD, GVE, GVHS**

Part	Steel 150# & 300#	316 S.S. 150# & 300#	CA-20 150#
Stator Liner	316L	316L	HAST C
Stator Band	STEEL	STEEL	STEEL
Stator End Bell	STEEL	STEEL	STEEL
End Bell Shroud	316L	316L	CA-20
Rotor Sleeve	316L	316L	HAST C
Rotor End Covers	316L	316L	CA-20
Shaft	316SS	316SS	CA-20
Front Bearing Housing	STEEL	316SS	CA-20
Front Bearing Housing (GVD)	316SS	316SS	CA-20
Rear Bearing Housing	316SS	316SS	CA-20
Bearings	CARBON GRAPHITE B SLEEVELESS		
Pump Casing	STEEL	316SS	CA-20
Discharge Filter	316SS	316SS	HAST C
Impeller (GA, GB, GC, GVD)	316SS	316SS	CA-20
Impeller (GVBS, GVHS, GVE, GG, GVM)	STEEL	316SS	CA-20
Circulating Tube Assembly	STEEL	316SS	CA-20
Gaskets	TEFLON ENVELOPE WITH STAINLESS STEEL INSERT		
Base	STEEL	STEEL	STEEL
Impeller Nut	316SS	316SS	CA-20
Drain Plugs	STEEL	316SS	CA-20
Internal Hardware	316SS	316SS	CA-20
External Hardware	STEEL	STEEL	STEEL

PARTS INTERCHANGEABILITY CHART

MODELS GA, GB, GC, GVBS

PART	GA 1K	GA 1.5K	GB 1.5K	GB 3K	GB 5K	GC 1.5K	GC 3K	GC 5K	GVBS 1.5K	GVBS 3K	GVBS 5K
STATOR ASSEMBLY	A	B	C	D	E	B	F	G	C	D	E
ROTOR ASSEMBLY	A	B	B	C	D	B	C	D	B	C	D
FRONT BEARING HOUSING	A	A	B	B	B	C	C	C	D	D	D
REAR BEARING HOUSING	A	A	A	A	A	A	A	A	A	A	A
BEARING, FRONT (THRUST SURFACE)	A	A	A	A	A	A	A	A	B	B	B
BEARING, REAR (THRUST SURFACE) *	A	A	A	A	A	A	A	A	A	A	A
BEARING, FRONT AND REAR (NON THRUST SURFACE) *	A	A	A	A	A	A	A	A	A	A	A
PUMP CASING	A	A	B	B	B	C	C	C	D	D	D
IMPELLER	A	A	B	B	B	C	C	C	D	D	D
CIRCULATION TUBE	A	B	C	D	E	F	G	H	I	J	K
PUMP CASING GASKET	A	A	B	B	B	A	A	A	B	B	B
MOTOR GASKET	A	A	A	A	A	A	A	A	A	A	A
IMPELLER NUT	A	A	A	A	A	A	A	A	A	A	A

* REAR BEARINGS OF A THRUST SURFACE PUMP ARE INTERCHANGABLE WITH THE FRONT AND REAR BEARINGS ON NON-THRUST SURFACE UNITS

MODELS GVD, GVE, GVHS

PART	GVD 5K	GVD 7.5K	GVD 10K	GVD 15K	GVD 20K	GVE 5K	GVE 7.5K	GVE 10K	GVE 15K	GVE 20K	GVHS 7.5K	GVHS 10K	GVHS 15K	GVHS 20K
STATOR ASSEMBLY	A	B	C	D	E	A	B	C	D	E	F	G	H	I
ROTOR ASSEMBLY	A	B	C	D	E	A	B	C	D	E	B	C	D	E
FRONT BEARING HOUSING	A	A	A	A	A	B	B	B	B	B	C	C	C	C
REAR BEARING HOUSING	A	A	A	A	A	A	A	A	A	A	A	A	A	A
BEARING, FRONT	A	A	A	A	A	A	A	A	A	A	A	A	A	A
BEARING, REAR	A	A	A	A	A	A	A	A	A	A	A	A	A	A
THRUST SURFACE	A	A	A	A	A	A	A	A	A	A	A	A	A	A
PUMP CASING	A	A	A	A	A	B	B	B	B	B	C	C	C	C
IMPELLER	A	A	A	A	A	B	B	B	B	B	C	C	C	C
CIRCULATION TUBE	A	B	C	D	E	F	G	H	I	J	K	L	M	N
PUMP CASING GASKET	A	A	A	A	A	A	A	A	A	A	B	B	B	B
MOTOR GASKET	A	A	A	A	A	A	A	A	A	A	A	A	A	A
IMPELLER NUT	A	A	A	A	A	A	A	A	A	A	A	A	A	A

COMMON LETTERS ON THE SAME HORIZONTAL LINE SIGNIFY THAT THE PART OR PARTS ARE INTERCHANGEABLE WITH EACH OTHER.

SERIES G CHEMPUMP

SUPERSEDES:

February 1, 1994

DATE:

January 19, 1999

PAGE

G-23

	GA	GB	GC	GVBS
IMPELLER				
Eye Area (sq. in.)	1.3	1.3	2.9	4.9
Vane Width	3/16 TAPERED	3/16 TAPERED	3/16 TAPERED	3/16 TAPERED
Wear Ring Dia. Front.	1.597 - 1.600	1.597 - 1.600	2.184 - 2.187	2.750 - 2.747
Wear Ring dia. (rear)	2.875 - 2.878	2.875 - 2.878	3.221 - 3.224	3.253 - 3.250
# of Vanes	5	5	5	4
PUMP CHAMBER				
Min Wall Thickness	5/16	3/8	5/16	3/8
P. C. Wear Ring Dia.	1.630 - 1.633	1.630 - 1.633	2.219 - 2.222	2.780 - 2.783
BEARINGS				
Bore Diameter	.9185 - .9175	.9185 - .9175	.9185 - .9175	.9185 - .9175
O. D.	1.837 - 1.836	1.837 - 1.836	1.837 - 1.836	1.837 - 1.836
THRUST SURFACE				
Length (front)	2.609	2.609	2.609	1-3/4
Length (rear)	1-3/4	1-3/4	1-3/4	1-3/4
NON-THRUST SURFACE				
Length (front)	1 - 3/4	1 - 3/4	1 - 3/4	1 - 3/4
Length (rear)	1 - 3/4	1 - 3/4	1 - 3/4	1 - 3/4
Overhang Length (C/L Brg. to C/L of Imp.)	2-1/16	2-1/8	2-1/4	2-3/4
Distance between Centers	4-5/8 (1K)	4-5/8 (1K)	4-5/8 (1K)	4-5/8 (1K)
	5-7/8 (1.5K)	5-7/8 (1.5K)	5-7/8 (1.5K)	5-7/8 (1.5K)
	7-3/8 (3K)	7-3/8 (3K)	7-3/8 (3K)	7-3/8 (3K)
	8-5/8 (5K)	8-5/8 (5K)	8-5/8 (5K)	8-5/8 (5K)
ROTOR				
Journal Diameter	.9143 - .9150	.9143 - .9150	.9143 - .9150	.9143 - .9150
End Play				
New (thrust surface)	.086 - .140	.086 - .140	.086 - .140	.083 - .107
New (non-thrust surface)	.084 - .104	.084 - .104	.084 - .104	.084 - .106
Min. clear. Imp. to P. C.	3/16	1/8	1/4	1/4
Min. clear. Imp. to F. B. H.	1/16	1/16	1/16	1/16
CLEARANCES (Diametrical)				
Imp wear Ring (Front)	.030 - .036	.030 - .036	.032 - .038	.030 - .036
Imp. Wear Ring (rear)	.057 - .063	.057 - .063	.060 - .066	.057 - .063
Liquid Gap in Rotor	.040	.040	.040	.040
Brg's to Journal (New)	.0025 - .0042	.0025 - .0042	.0025 - .0042	.0025 - .0042
Brg's to Journal (Mas. Allow)	.013	.013	.013	.013
Shaft to Brg. Housing I. D.	.0220 - .0247	.0220 - .0247	.0220 - .0247	.0220 - .0247
Shaft Clearance Hole	.937 - .939	.937 - .939	.937 - .939	.937 - .939
OTHER				
Stator Liner Thickness	.015	.015	.015	.015
Rotor Sleeve Thickness	.015	.015	.015	.015
Rotor End Cover Thickness	1/16	1/16	1/16	1/16

ALL DIMENSIONS LISTED ARE IN INCHES

SERIES G CHEMPUMP

SUPERSEDES:

DATE:

PAGE

February 1, 1994

January 19, 1999

G-24

	GVD	GVE	GVHS
IMPELLER			
Eye Area (sq. in.)	3.9	5.9	3.9
Vane Width	11/32	1/2 TAPERED	11/32
Wear Ring Dia. Front.	2.622 - 2.625	5.446 - 5.449	5.497 - 5.500
Wear Ring dia. (rear)	5.421 - 5.424	6.754 - 6.757	6.754 - 6.757
# of Vanes	5	4	5
PUMP CHAMBER			
Min Wall Thickness	1/2	1/2	1/2
P. C. Wear Ring Dia.	2.571 - 2.574	5.507 - 5.510	5.558 - 5.561
BEARINGS			
Bore Diameter	1.188 - 1.189	1.188 - 1.189	1.188 - 1.189
O. D.	2.312 - 2.313	2.312 - 2.313	2.312 - 2.313
THRUST SURFACE			
Length (front)	4	4	4
Length (rear)	2	2	2
NON-THRUST SURFACE			
Length (front)	4	4	4
Length (rear)	2	2	2
Overhang Length (C/L Brg. to C/L of Imp.)	4-3/4	4-3/4	4-9/16
Distance between Centers	9-5/8 (5K)	9-5/8 (5K)	9-5/8 (5K)
	10-5/8 (7.5K)	10-5/8 (7.5K)	10-5/8 (7.5K)
	11-5/8 (10K)	11-5/8 (10K)	11-5/8 (10K)
	12-5/8 (15K)	12-5/8 (15K)	12-5/8 (15K)
	14-5/8 (20K)	14-5/8 (20K)	14-5/8 (20K)
ROTOR			
Journal Diameter	1.183 - 1.184	1.183 - 1.184	1.183 - 1.184
End Play			
New	.012 - .042	.084 - .104	.022 - .042
Min. clear. Imp. to P. C.	.032 - .068	.101 - .137	.032 - .068
Min. clear. Imp. to F. B. H.	1/8	3/32	1/8
CLEARANCES (Diametrical)			
Imp wear Ring (Front)	.048 - .054	.058 - .064	.058 - .064
Imp. Wear Ring (rear)	.037 - .045	.039 - .045	.039 - .045
Liquid Gap in Rotor	.040	.040	.040
Brg's to Journal (New)	.0040 - .0058	.0040 - .0058	.0040 - .0058
Brg's to Journal (Mas. Allow)	.014	.014	.014
Shaft to Brg. Housing I. D.	.0360 - .0377	.0360 - .0377	.0360 - .0377
Shaft Clearance Hole	1.220 - 1.221	1.220 - 1.221	1.220 - 1.221
OTHER			
Stator Liner Thickness	.015	.015	.015
Rotor Sleeve Thickness	.015	.015	.015
Rotor End Cover Thickness	1/16	1/16	1/16

All dimensions are listed in inches.