



BY JOHNSON CONTROLS

070.510-SPC (MAR 2013)

## SPECIFICATIONS

File: EQUIPMENT MANUAL - Section 70  
Replaces: 070.510-SPC (OCT 2011)  
Dist: 10

# ROTARY SCREW COMPRESSORS

## Models XJF/XJS 95 through 151

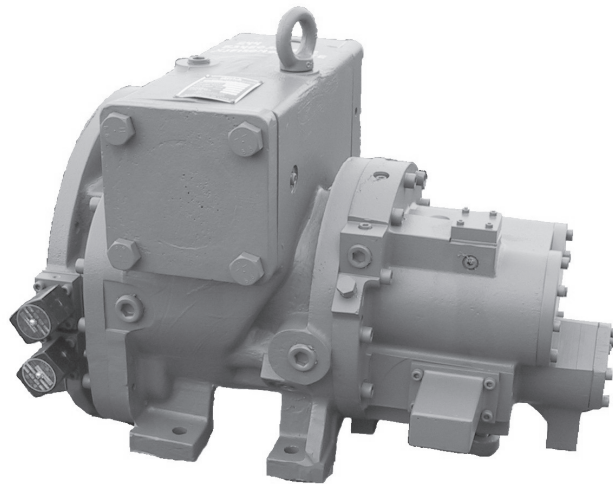

XJF

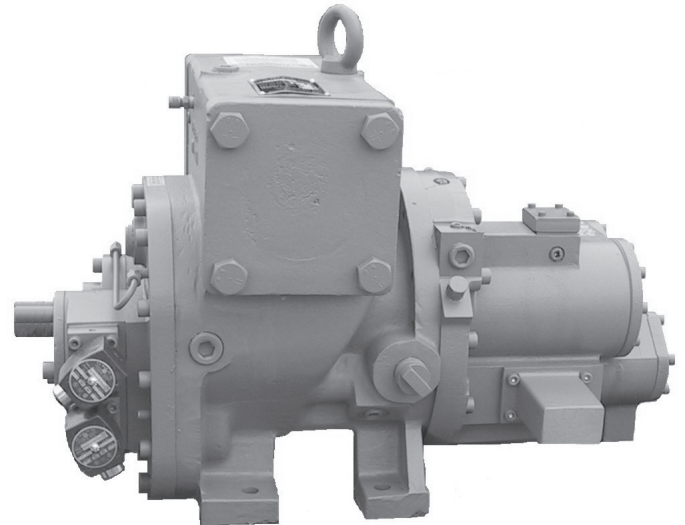

XJS

### SPECIFICATIONS

The Frick® XJS/XJF screw compressor is designed to compress a variety of gases in many different applications including refrigeration, air conditioning, water chilling, wellhead compression, gas gathering, and vapor recovery. Applications include booster duty (low temperature/pressure), high (single) stage, or swing duty compression.

**Stepless Capacity Control** - A hydraulically or manually actuated slide valve moves axially along the rotor mesh line to provide unloading down to 25% of full load capacity. Unloaded gas is bypassed back to suction before compression has begun, allowing the compressor to efficiently accommodate system requirements.

**Variable Volume Ratio** - A hydraulically actuated slide stop adjusts slide valve length to the most efficient of three possible volume ratios. This closely matches compressor volume ratio to system pressure ratio and minimizes the power penalties associated with under- or overcompression.

**Antifriction Bearings** - Cylindrical roller bearings handle radial loads and four-point angular contact ball bearings, aided by balance pistons (in some cases), absorb thrust loads. No preloading is required. At design conditions, L<sub>10</sub> life is in excess of 100,000 hours. Roller bearings also maintain superior rotor positioning to minimize internal leakage and provide excellent performance. System differential pressure is normally sufficient as the driving force to supply oil to the bearings,

thereby eliminating the need for an oil pump. Antifriction bearings have lower frictional horsepower requirements for lower power consumption. Compressor housings are machined to provide static oil reservoirs for the bearings.

**Oil Injection** - Injected oil serves to lubricate the bearings, balance piston, and seal, fill any leakage paths between and around the rotors to prevent gas bypassing, and maintain superior efficiencies. Oil injection minimizes noise and vibration and keeps the compressor cool to prevent overheating by absorbing much of the heat from compression.

**Close-Coupled Motor** - XJF 95/120 model compressors are supplied with a C-flange adaptor. XJF 151 model compressors are available with a C-flange/D-flange adaptor as an option. This allows direct connection to a motor guaranteeing coupling alignment without requiring field labor.

**Dynamically Balanced** - Rotors and rotating parts are dynamically balanced to demanding requirements providing low vibration from high speed rotation.

**Made in the USA** - The entire compressor is designed and built in Waynesboro, PA. Expert engineering, automated machining centers, clean temperature controlled assembly, and stringent quality control requirements (ISO 9001) all contribute to assuring easy installation, reliable operation, and convenient servicing.

Check [www.johnsoncontrols.com/frick](http://www.johnsoncontrols.com/frick) for the latest version of this publication.

### MATERIALS OF CONSTRUCTION

**Castings** - ASTM A48 class 40 gray cast iron is standard for pressure-retaining parts. Suction and discharge flanges are 400 psig design.

Alternate casing material is ductile iron grade 60-40-18 per ASTM A395 and ASME SA 395 including a Charpy V-notch test at room temperature and a material certificate type 3.1 per EN 10204. Material is similar to European standard EN 1563, material designation EN-GJS-400-18.

**Rotors** - AISI-1141 low carbon steel, machined from hot-rolled bar stock. Permissible residual unbalance of Rotors meet requirement of ISO 1940 grade 2.5.

**Drive Shaft** - Jackshaft is made of AISI 1144 carbon steel.

**Gears** - 4140H steel, through hardened to 32-36 Rockwell "C". Nitride case hardened. ANSI/AGMA 2000 - A88 specifications. Gears are dynamically balanced to class G2.5 (ISO 1940).

**Bearings** - Rolling elements and rings are AISI-52100 medium carbon alloy steel. Cages are brass, polyamide, or steel. Tolerance quality complies with ABEC 1 through 3.

**Slide Valve Indicator** - Type 304 stainless steel, aluminum rod with steel tip. Transmitter 4-20 mA.

**Slide Valve, Slide Stop, Pistons, Spacers, Etc.** - Fabricated from class 40 gray cast iron.

**Retaining (Snap) Rings & Spring Washers** - High carbon spring steel.

**Bolts** - Grade 8.8, heat treated, medium carbon steel, socket head cap screws.

**Static Seals** - HNBR O-rings. Viton® also available.

**Dynamic Seals** - Carbon filled teflon.

**Shaft Seal** - Spring-loaded, stationary, carbon end face with a stainless steel carrier against a rotating nonmagnetic cast iron alloy floating seat. The assembly is fully balanced and is vented to low pressure to extend seal life. Secondary seals are HNBR or Viton® O-rings.

### TYPICAL PERFORMANCE

Model	R-507 (HCFC)				R-717 (Ammonia, NH <sub>3</sub> )				Natural Gas (SG=.65, k=1.26)			
	Capacity		Power		Capacity		Power		Capacity		Power	
	TR	kW	BHP	kW	TR	kW	BHP	kW	MMSCFD	MSCMH	BHP	kW
95S	51	179	68	51	51	179	62	46	0.139	0.164	14	10
95M	29	102	42	31	29	102	38	28	0.071	0.084	8	6
95L	37	130	52	39	38	134	47	35	0.096	0.113	10	7
120S	104	365	139	104	105	369	126	94	0.297	0.350	27	20
120M	61	214	84	63	61	214	76	57	0.158	0.186	17	13
120L	78	274	105	78	78	274	95	71	0.211	0.249	21	16
151A	123	432	156	116	120	422	143	107	0.350	0.413	29	22
151M	148	520	185	138	144	506	170	127	0.431	0.509	35	26
151L	187	657	232	173	182	640	213	159	0.549	0.648	43	32
151N	225	791	282	210	220	773	259	193	0.662	0.781	51	38

**NOTES:**

1. SG=Specific Gravity, k=Ratio of Specific Heats (Cp/Cv), TR=Tons Refrigeration, kW=Kilowatts, BHP=Brake Horsepower, MMSCFD=Millions Standard Cubic Feet per Day, MSCMH=Thousands Standard Cubic Meters per Hour.
2. R-507 ratings based on 20°F (-6.7°C) suction and 95°F (35°C) condensing with 10°F (5.5°C) liquid subcooling and 10°F (5.5°C) suction superheat contributing to refrigeration effect at 3550 RPM.
3. R-717 ratings based on 20°F (-6.7°C) suction and 95°F (35°C) condensing with 10°F (5.5°C) liquid subcooling and 10°F (5.5°C) suction superheat contributing to refrigeration effect at 3550 RPM.
4. Natural gas ratings based on 25 PSIA (172 kPaA), 80°F (27°C) suction and 75 PSIA (517 kPaA) discharge at 1800 RPM.

**MODEL NUMBER EXPLANATION**

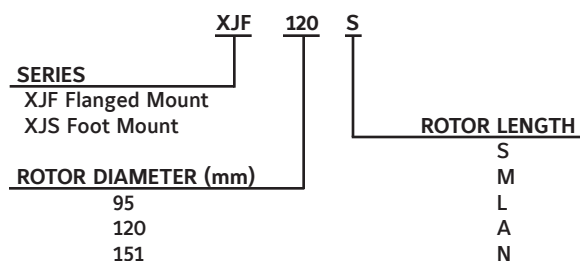

DESIGN LIMITATIONS AND MECHANICAL CHARACTERISTICS

	COMPRESSOR MODEL									
	95S	95M	95L	120S	120M	120L	151A	151M	151L	151N
Approx Compr. Wt. lb (kg)	XJS = 460 (209) XJF = 660 (299)			XJS = 670 (305) XJF = 840 (380)			XJS = N/A XJF = 1195 (542)			
Rotor Dia. mm	95			120			151			
Gear Ratio (Drive:Pinion)	Male rotor driven by integral gear set									
	66:31	55:42	60:37	66:31	55:42	60:37	51:46	55:42	60:37	64:33
Minimum Driver Speed <sup>(1)(2)</sup> RPM	600 <sup>(1)(2)</sup>									
Maximum Driver Speed RPM	3550	5772	4661	3550	5772	4661	6297	5332	4306	3600
Max. Input Power to Rotor Shaft BHP (KW)	100 (75)			208 (155)			400 (298)			
Min. Breakaway Torque ft-lb (Nm)	3 (4.1)			4 (5.4)			5 (6.8)			
Mass Moment of Inertia <sup>(3)</sup> ft <sup>2</sup> -lb <sub>m</sub> (m <sup>2</sup> -kg)	.9 (.038) <sup>(3)</sup>	.38 (.016) <sup>(3)</sup>	.55 (.023) <sup>(3)</sup>	2.2 (.093) <sup>(3)</sup>	.88 (.037) <sup>(3)</sup>	1.3 (.055) <sup>(3)</sup>	2.7 (.114) <sup>(3)</sup>	3.6 (.154) <sup>(3)</sup>	5.4 (.228) <sup>(3)</sup>	7.6 (.319) <sup>(3)</sup>
Suction Flange in. (mm)	2-1/2 (64)		3 (96)	4 (102) <sup>(4)</sup>			5 (127)			
Discharge Flange <sup>(5)</sup> in. (mm)	XJS=Side XJF=Bottom 2 1/2 (64) <sup>(5)</sup>			XJS=Side XJF=Side or Bot. 3 (76) <sup>(5)</sup>			XJS=N/A XJF=Bottom 4 (102) <sup>(5)</sup>			
Theoretical Displacement ft <sup>3</sup> /rev. (m <sup>3</sup> /rev.)	.040864 (.001157)	.025134 (.000712)	.031125 (.000881)	.082343 (.002332)	.050648 (.001434)	.062718 (.001776)	.09623 (.002725)	.11366 (.003219)	.14075 (.003986)	.16833 (.004767)
Displ. at 3550 rpm Driver Speed ft <sup>3</sup> /min (m <sup>3</sup> /hr)	145 (247)	89 (152)	111 (188)	292 (497)	180 (306)	223 (378)	342 (580)	404 (686)	500 (849)	598 (1015)
Displ. at 2950 rpm Driver Speed ft <sup>3</sup> /min (m <sup>3</sup> /hr)	121 (205)	74 (126)	92 (156)	243 (413)	149 (234)	185 (314)	284 (482)	335 (570)	415 (706)	497 (844)
Displ. at 1750 rpm Driver Speed ft <sup>3</sup> /min (m <sup>3</sup> /hr)	72 (122)	44 (75)	54 (93)	144 (245)	89 (151)	110 (187)	168 (286)	199 (338)	246 (419)	295 (501)
Displ. at 1450 rpm Driver Speed ft <sup>3</sup> /min (m <sup>3</sup> /hr)	59 (101)	36 (62)	45 (77)	119 (203)	73 (125)	91 (155)	140 (237)	165 (280)	204 (347)	244 (415)
Capacity Control	Infinitely adjustable from 100% to 25% by piston- or handwheel- (except 95) actuated slide valve									
Volume Ratio	Variable in 3 steps: 2.2, 3.5, 5.0									
Max. Inlet Press. psia (bara)	100 (6.9)						150 (10.3)			
Max. Outlet Press. psia (bara) <sup>(7)</sup>	400 (27.6) <sup>(7)</sup>									
Max. Outlet Press. psia (bara) <sup>(8)</sup>	600 (41.4) <sup>(8)</sup>									
Minimum Inlet Temp. <sup>(6)</sup> °F (°C)	-76 (-60) <sup>(6)</sup>									
Maximum Inlet Temp. <sup>(6)</sup> °F (°C)	200 (93.3) <sup>(6)</sup>									
Maximum Outlet Temp. <sup>(6)</sup> °F (°C)	250 (121) <sup>(6)</sup>									
Maximum Temp. Dif. (Suct. to Disch.) °F (°C)	250 (121)									
Max. Bearing Oil Supply Temp. °F (°C)	230 (110)									

1. Contingent upon compression ratio, bearing L10 limitations, oil viscosity, and other operating conditions.
2. Compressor suction flow may be zero at full unload slide valve position below 1800 RPM.
3. Does not include coupling. Resolved to drive shaft.
4. A 3 in. suction flange is installed on 120S compressors if operating at 1750 or 1450 rpm.
5. XJS and XJF discharge casings are interchangeable within a model size to allow selection of discharge flange orientation.
6. At compressor suction flange. Minimum evaporator temperature can be lower.
7. Standard ASTM A48 class 40 gray cast iron housing. Some models capable of higher pressures. Consult factory.
8. ASTM A395 grade 60-40-18 ductile iron housings. .

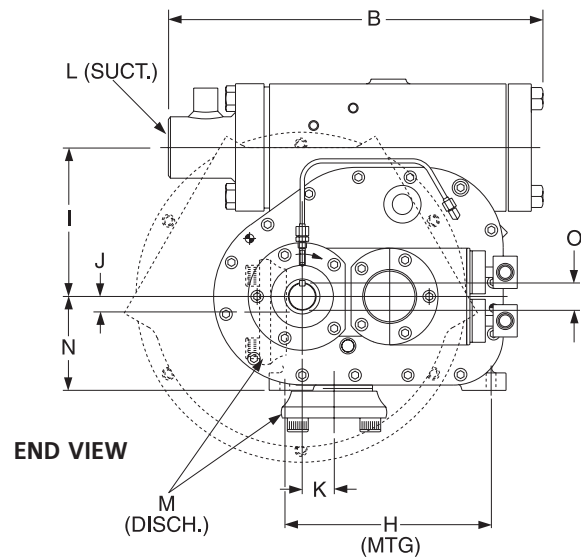
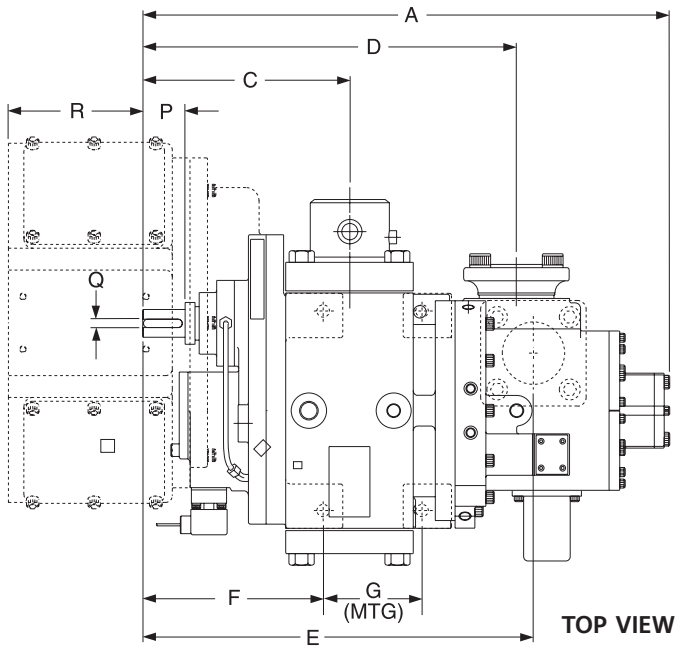

**NOTES:**

1. An XJS120 is shown for illustrative purposes only. Configurations of other compressor sizes vary slightly.
2. The suction connection may be moved to the other side.
3. The XJF151 has 3 pads instead of 4 feet for mounting.

**DIMENSIONAL OUTLINE**

DIM	DESCRIPTION	95mm		120mm		151mm	
		in	mm	in	mm	in	mm
A	Compressor length (shaft end to bolt)	25.63	651	30.02	763	43.63	1108
B	Compressor width (stubout to bolt w/o sealing disk)	22.94	583	23.37	594	29.23	743
C	Suction CL to shaft end	10.87	276	11.77	299	19.56	497
D	Discharge CL (side) to shaft end	18.57	472	21.27	540	N/A	N/A
E	Discharge CL (bottom) to shaft end	18.44	468	21.90	556	31.10	790
F	Shaft end to rear mounting holes	9.31	237	10.15	258	13.19	335
G	Mounting holes length between centers	4.06	103	5.62	143	12.56	319
H	Mounting holes width between centers, drive end	10.62	270	11.24	286	7.50	190
H	Mounting holes width between centers, nondrive end	10.62	270	11.24	286	2.25	57
I	Suction CL to shaft CL	6.93	176	8.47	215	10.70	272
J	Discharge CL (side) to shaft CL	1.38	35	0.97	25	N/A	N/A
K	Discharge CL (bottom) to shaft CL	4.34	110	1.83	47	6.09	155
L	Suction diameter, S	2.50	64	3.00	76	5.00	127
L	Suction diameter, M	2.50	64	4.00	102	5.00	127
L	Suction diameter, L	3.00	76	4.00	102	5.00	127
M	Discharge diameter	2.50	64	3.00	76	4.00	102
N	Shaft CL to base	4.72	120	5.34	136	5.80	147
O	Shaft diameter	1.38	35	1.58	40	2.00	51
P	Shaft length available for coupling, XJS	2.02	51	2.42	62	N/A	N/A
P	Shaft length available for coupling, XJF	2.02	51	2.24	57	3.86	98
Q	Keyway width	0.39	10	0.47	12	0.50	13
R	Motor adapter length from shaft end	6.87	175	7.48	190	8.13	207